

Commercial eF Series® Ultra High Efficiency Gas Water Heater



The eF Series® Models feature:

- **Thermal Efficiency up to 99.1%**—Ultra High Efficiency results in less fuel consumption and greater hot water recovery.
- **ICON HD™**—Intelligent proven design combines temperature control, diagnostic codes, and system ignition functions into a single control board with a digital LCD display.
- **ENERGY STAR® Models Available**—EF60T125 & EF100T (150,199,250,399) Models.
- **Factory Installed Hydrojet® Sediment Reduction System**—Cold water inlet sediment reducing device helps prevent sediment build up in the tank.
- **Direct Spark Ignition**—For improved operational dependability and durability.
- **Operation Mode**—Two different digitally displayed operation modes have the capability of adjusting the temperature setting up to 180°F (82°C), and adjusting the degree setting (°F to °C, or °C to °F).
- **Service Mode**—Eight different digitally displayed service screens can be easily cycled through by pressing the select button. There is the capability of adjusting the temperature setting up to 180°F (82°C), adjusting the degree setting (°F to °C, or °C to °F), locking the maximum temperature setting that can be adjusted in operation mode, displaying the temperature sensor reading, displaying the flame current, and displaying diagnostic codes.
- **Premix Power Burner**—A self compensating negative regulation system automatically increases or decreases fuel flow when a change in combustion air is detected. This provides the range for optimum combustion and efficiency (automatic high altitude compatibility).
- **Flexible Venting**—The eF Series® can vent vertically or horizontally with either 2", 3" or 4" PVC, CPVC or ABS (not approved for Canada) vent pipe, and is approved for direct vent closed combustion applications, or those applications that require inside air for combustion. Foam Core pipe is permitted on the entire venting system. The eF Series® is also approved for unbalanced venting, which means the air intake pipe doesn't have to be vented the same distance as the exhaust.
- **Ultra Quiet Operation.**
- **A Single Exhaust Pressure Switch.**
- **1" NPT Side Connections for Space Heating.**
- **Sanitizing Capability**—Temperature setting up to 180°F (82°C).
- **Complies with the latest ultra-low NOx requirement (14 ng/J NOx limit).**
- **ASME Code Available on All Models.**
- **NSF Construction Available.**
- **T&P Relief Valve**—Installed.
- **Low Restrictive Brass Drain Valve**—Durable tamper proof design.



Photo is of
EF-60T-199E-3N

FEATURING:



3 or 5-Year Limited Tank Warranties / 1-Year Limited Warranty on Component Parts.

For more information on warranty, please visit www.bradfordwhite.com
For products installed in USA, Canada and Puerto Rico. Some states do not allow limitations on warranties.
See complete copy of the warranty included with the heater.

Commercial Gas High Efficiency Water Heater

eF Series® Additional Equipment Features:

Three Pass Heat Exchanger System—The three pass Heat Exchanger system keeps the hot combustion gases moving at a high velocity. The combination of high turbulence and velocity causes an enormous rate of heat transfer into the water.

Submerged Combustion Chamber—Submerging the combustion chamber in the center of the water storage tank minimizes radiant heat loss and improves efficiency.

Zero Inch Clearance—The eF Series® jacket is cool to the touch and is approved for zero inch clearance to combustibles for unsurpassed installation flexibility.

Vitraglas® Lining—Bradford White tanks are lined with an exclusively engineered enamel formula that provides superior tank protection from the highly corrosive effects of hot water. This formula (Vitraglas®) is fused to the steel surface by firing at a temperature of over 1600°F (871°C).

Magnesium Anode Rods—Each eF Series® model has multiple anodes to provide added protection against corrosion for long trouble-free service (EF100T399 has two powered anode rods).

Factory Installed Hydrojet® Sediment Reduction System—Cold water inlet sediment reducing device helps prevent sediment build up in tank.

Water Connections—Factory installed true dielectric waterway fittings extend water heater life and eases installation.

Hand Hole Cleanout—Allows inspection of tank interior and facilitates the removal of sediment deposits.

E.C.O.—A manual re-set Energy Cut Off (E.C.O) shuts off all gas in event of an overheat condition. The ECO is manually resettable.

Non-CFC Foam Insulation—Covers the sides and top of tank, reducing the amount of heat loss. This results in less energy consumption, improved operation efficiencies and jacket rigidity.

2" Vent Pipe	EF-60T-125		EF-60T-150 EF-100T-150		EF-60T-199 EF-100T-199					
	Power Direct Vent	Power Vent	Power Direct Vent	Power Vent	Power Direct Vent	Power Vent	Power Direct Vent	Power Vent	Power Direct Vent	Power Vent
Max. Intake Length	15 ft.	N/A	15 ft.	N/A	15 ft.	N/A	15 ft.	N/A	15 ft.	N/A
Max. Exhaust Length	15 ft.	30 ft.	15 ft.	30 ft.	15 ft.	30 ft.	15 ft.	30 ft.	15 ft.	30 ft.

3" Vent Pipe	EF-60T-125 EF-100T-150		EF-60T-150 EF-100T-199		EF-60T-199 EF-100T-250		EF-100T-300		EF-100T-399	
	Power Direct Vent	Power Vent	Power Direct Vent	Power Vent	Power Direct Vent	Power Vent	Power Direct Vent	Power Vent	Power Direct Vent	Power Vent
Max. Intake Length	60 ft.	N/A	50 ft.	N/A	40 ft.	N/A	30 ft.	N/A	25 ft.	N/A
Max. Exhaust Length	60 ft.	120 ft.	50 ft.	100 ft.	40 ft.	80 ft.	30 ft.	60 ft.	25 ft.	50 ft.

4" Vent Pipe	EF-60T-125 EF-100T-150		EF-60T-150 EF-100T-199		EF-60T-199 EF-100T-250		EF-100T-300		EF-100T-399	
	Power Direct Vent	Power Vent	Power Direct Vent	Power Vent	Power Direct Vent	Power Vent	Power Direct Vent	Power Vent	Power Direct Vent	Power Vent
Max. Intake Length	85 ft.	N/A	75 ft.	N/A	65 ft.	N/A	55 ft.	N/A	50 ft.	N/A
Max. Exhaust Length	85 ft.	170 ft.	75 ft.	150 ft.	65 ft.	130 ft.	55 ft.	110 ft.	50 ft.	100 ft.

6" Vent Pipe	EF-100T-399	
	Power Direct Vent	Power Vent
Max. Intake Length	120 ft.	N/A
Max. Exhaust Length	120 ft.	240 ft.

Air intake cannot exceed exhaust by more than 30 ft. in any venting situation. Subtract 5 ft. for each additional 90° elbow.

eF Series® Optional Equipment Features:

Maxitrol Gas Pressure Regulating valve—Ensures proper supply pressure to eF unit of 7" to 11" W.C. (provided incoming pressure is between 1/2 and 2 psi). This can be ordered as a separate part, or as part of the heater. For the separate part, please use p/n 243-45517-00. Part is included with EF100T399 model.

NSF Compliance Kit—p/n 265-44542-04.

Low Inlet Gas Pressure Option—Pre-assembled to allow operation with natural gas inlet pressure down to 3.5" w.c. (Not available on EF-100T-300/399E-3N(A) models or any size propane models.)

Concentric Vent Kit Termination—3" termination fitting provides for only one exit opening through wall or roof (p/n 239-44069-01).

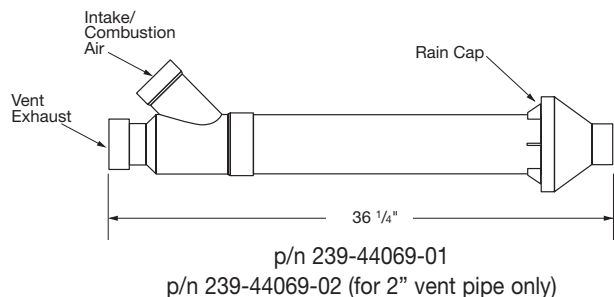

Commercial Gas High Efficiency Water Heater

eF Series® Models

NATURAL GAS AND LIQUID PROPANE GAS

Meet or exceed ASHRAE 90.1b (current standard) C.E.C. Listed

Model Number	Capacity		Input		GPH Recovery at Degree Rise*			Therm. Eff. %	A Floor to Top of Heater in.	B Jacket Dia. in.	C Floor to Hot Water Conn. in.	D Floor to Cold Water Conn. in.	E Floor to Gas Conn. in.	F Floor to Vent Conn. in.	G Floor to Air Intake Conn. in.	H Floor to T&P Conn. in.	Water Conn. Dia. in.	Gas Conn. Dia. in.	Relief Valve Open in.	Approx. Shipping Weight lbs.
	U.S. Gal.	Imp. Gal.	Nat. BTU/Hr. Input	LP BTU/Hr. Input	40°F	100°F	140°F													
EF-60T-125E-3N(A)	60	50	125,000	125,000	364	145	104	96.0	57	28 1/4	42 1/2	12 7/8	53 1/2	5	52 1/2	40	1 1/2	3/4	3/4	570
EF-60T-150E-3N(A)	60	50	150,000	150,000	423	169	121	93.0	57	28 1/4	42 1/2	12 7/8	53 1/2	5	52 1/2	40	1 1/2	3/4	3/4	570
EF-60T-199E-3N(A)	60	50	199,999	199,999	558	223	159	92.0	57	28 1/4	42 1/2	12 7/8	53 1/2	5	52 1/2	40	1 1/2	3/4	3/4	570
EF-100T-150E-3N(A)	100	83	150,000	150,000	450	180	129	99.1	77 5/8	28 1/4	62 1/2	12 7/8	74 3/4	5	73 1/8	60	1 1/2	3/4	3/4	900
EF-100T-199E-3N(A)	100	83	199,999	199,999	597	239	171	98.5	77 5/8	28 1/4	62 1/2	12 7/8	74 3/4	5	73 1/8	60	1 1/2	3/4	3/4	900
EF-100T-250E-3N(A)	100	83	250,000	250,000	735	294	210	97.0	77 5/8	28 1/4	62 1/2	12 7/8	74 3/4	5	73 1/8	60	1 1/2	3/4	1	900
EF-100T-300E-3N(A)	100	83	300,000	300,000	836	335	239	92.0	77 5/8	28 1/4	62 1/2	12 7/8	74 3/4	5	73 1/8	60	1 1/2	3/4	1	900
EF-100T-399E-3N(A)	100	83	399,999	399,999	1127	451	322	94.0	77 5/8	28 1/4	63	13	74 1/4	5	73 1/8	60	1 1/2	1	1	950

Model Number	Capacity		Input		LPH Recovery at Degree Rise*			Therm. Eff. %	A Floor to Top of Heater mm.	B Jacket Dia. mm.	C Floor to Hot Water Conn. mm.	D Floor to Cold Water Conn. mm.	E Floor to Gas Conn. mm.	F Floor to Vent Conn. mm.	G Floor to Air Intake Conn. mm.	H Floor to T&P Conn. mm.	Water Conn. Dia. mm.	Gas Conn. Dia. mm.	Relief Valve Open mm.	Approx. Shipping Weight kgs.
	Liters		Nat. kW/Hr. Input	LP kW/Hr. Input	22°C	56°C	78°C													
EF-60T-125E-3N(A)	227		36.6	36.6	1378	549	394	96.0	1448	718	1087	327	1359	127	1334	1016	38	19	19	259
EF-60T-150E-3N(A)	227		43.9	43.9	1601	640	458	93.0	1448	718	1087	327	1359	127	1334	1016	38	19	19	259
EF-60T-199E-3N(A)	227		58.6	58.6	2112	844	602	92.0	1448	718	1087	327	1359	127	1334	1016	38	19	19	259
EF-100T-150E-3N(A)	379		43.9	43.9	1703	681	488	99.1	1972	718	1588	327	1899	127	1857	1524	38	19	19	408
EF-100T-199E-3N(A)	379		58.6	58.6	2260	905	647	98.5	1972	718	1588	327	1899	127	1857	1524	38	19	19	408
EF-100T-250E-3N(A)	379		73.2	73.2	2782	1113	795	97.0	1972	718	1588	327	1899	127	1857	1524	38	19	25	408
EF-100T-300E-3N(A)	379		87.9	87.9	3165	1268	905	92.0	1972	718	1588	327	1899	127	1857	1524	38	19	25	408
EF-100T-399E-3N(A)	379		117.2	117.2	4266	1707	1219	94.0	1972	718	1600	330	1861	127	1857	1524	38	25	25	431

For propane gas models change suffix "N" to "X" and remove "E" from the model number. **Example: EF-100T-150-3X**

(A) ASME - All models are available with ASME construction. To order ASME construction add the (A) to the end of the model number.

Example: EF-60T-125E-3NA

Note: The weight is the same for both ASME and Non-ASME models. All models comply with the latest ultra-low NOx requirements of 14 ng/J or less.

Amp Draw range = 1.0 to 1.8 amps.

14.0" w.c. maximum static, 4.5" w.c. minimum running (recommend 7.0" w.c. minimum running)

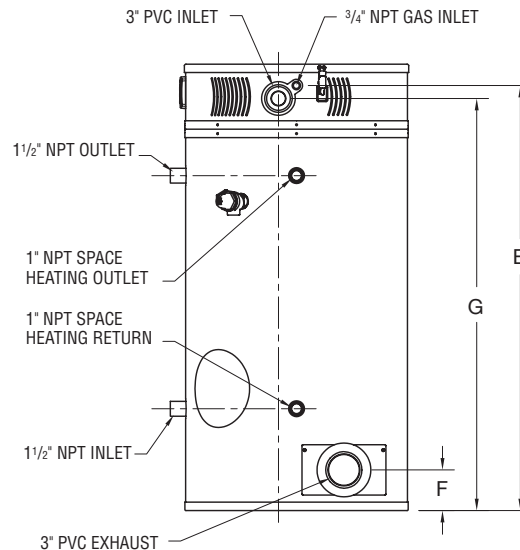
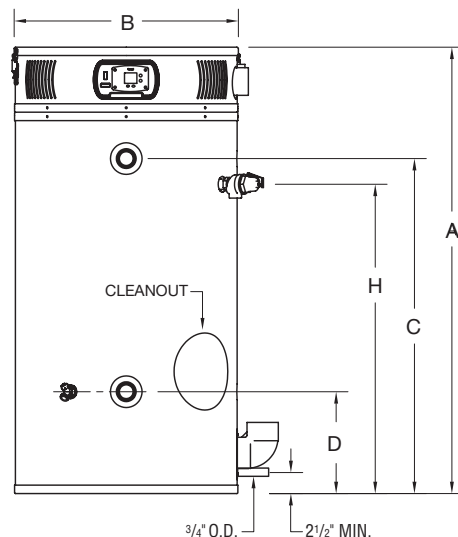
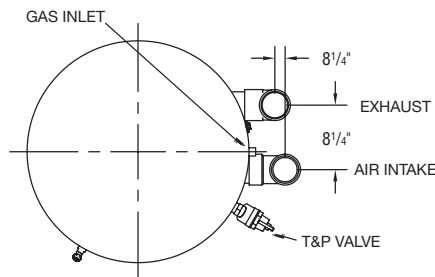

Note: Diagrams are for both 60 and 100 gallon models.

Commercial Gas High Efficiency Water Heater

Sample Specification

The water heater shall be a Bradford White model EF-_____ with a rated storage capacity of not less than _____ gallons/ liters, a minimum gas input of _____ BTU/hr., a minimum recovery of _____ GPH/LPH at 100°F (56°C) temperature rise, and a Thermal Efficiency Rating of ____%. It shall be design certified by CSA International (formerly AGA and CGA) for 180°F (82°C) application, either with or without a separate storage tank. The tank shall be lined with Vitraglas® vitreous enamel and shall have a bolted hand hole cleanout. The tank shall have four extruded magnesium anode rods installed in separate head couplings. This water heater shall be equipped with stainless steel cold water inlet, Hydrojet® Sediment Reduction System. The heater shall be insulated with Non-CFC foam. This water heater shall be equipped with an electronic ignition system, an ASME rated T&P relief valve and a premix closed combustion system for direct venting using either 3" (76mm) or 4" (102mm) PVC, CPVC or ABS vent pipe. (115V AC required). The water heater shall be factory assembled and tested. The water heater shall be approved for zero inch clearance to combustibles. A digital LCD display shall be integrated into the front and be an adjustable electronic thermostat to any temperature up to 180°F. A recycling Energy Cut Off (E.C.O.) shuts off all gas in the event of an overheat condition. The entire installation shall be made in compliance with state and local codes and ordinances.

General

All gas water heaters are certified at 300 PSI test pressure (2068 kPa) and 150 PSI working pressure (1034 kPa). All models are design certified by CSA International (formerly AGA/CGA), ANSI standard Z-21.10.3, for up to 180°F (82°C) application as an Automatic Storage Heater. As an Automatic Storage Heater, all models are complete, self-contained water heating systems. It needs no separate storage tank, pump, wiring or elaborate piping network. When equipped with a mixing valve, it will supply 180°F (82°C) sanitizing and lower temperature general purpose hot water simultaneously. These models can be used either as a single unit or in multiples connected in series or parallel (recommended).

Dimensions and specifications subject to change without notice in accordance with our policy of continuous product improvement.



Ambler, PA

For U.S. and Canada field service, contact your professional installer or local Bradford White sales representative.

Sales 800-523-2931 • Fax 215-641-1670 / Technical Support 800-334-3393 • Fax 269-795-1089 • Warranty 800-531-2111 • Fax 269-795-1089

International: Telephone 215-641-9400 • Telefax 215-641-9750 / www.bradfordwhite.com

 **BRADFORD WHITE-CANADA**® INC. Sales / Technical Support 866-690-0961 / 905-238-0100 • Fax 905-238-0105 / www.bradfordwhite.com

Built to be the Best™

©2016, Bradford White Corporation. All rights reserved.